

Flange Serrated Nut

Thread Type: Metric - Coarse

Thread Direction: Right Hand

Material: Carbon Steel

Class Grade: High Tensile Class 8

Finish: Zinc Yellow

Corrosion Protection Level: Moderate

Standard: DIN 6923

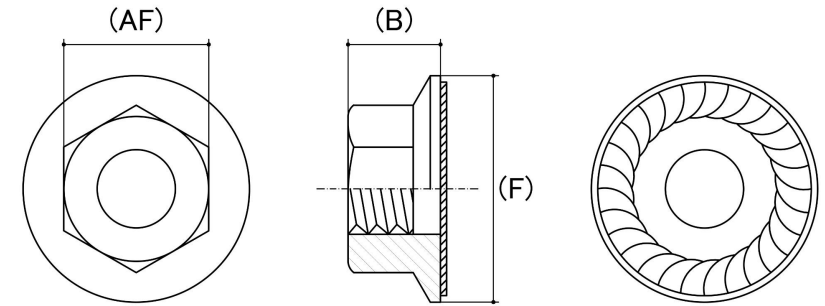

*CAD drawings shown for graphic representation only.**

Size	Thread Pitch (mm)	Thread Type	Overall Nut Height (B) (mm)		Flange Diameter (F) (mm)		Across Flats (AF) (mm)		Spanner Size (AF) (mm)	sku (qfind)
			Min	Max	Min	Max	Min	Max		
M4	0.70	Coarse	4.35	4.65	9.60	10.00	6.78	7.00	7	41FL4ZY
M5	0.80	Coarse	4.70	5.00	11.50	11.90	7.78	8.00	8	41FL5ZY
M6	1.00	Coarse	5.64	6.00	12.70	13.30	9.78	10.00	10	41FL6ZY
M8	1.25	Coarse	7.60	8.00	16.50	17.30	12.73	13.00	13	41FL8ZY
M10	1.50	Coarse	9.60	10.00	20.50	21.30	14.73	15.00	15	41FL10ZY
M12	1.75	Coarse	11.60	12.00	24.60	25.80	17.73	18.00	18	41FL12ZY
M16	2.00	Coarse	15.30	16.00	33.80	35.00	23.67	24.00	24	41FL16ZY

Disclaimer:

Dimensional data and technical information was obtained from publically available sources and not acquired through standard agencies. It has been completed and compiled for reference purposes only; where discrepancies are found they are subject to change without notice. Bolt & Nut Australia makes no warranties or representations regarding the accuracy and validity of the compiled information and data. Contact the relevant standard authorities for accurate and detailed information.

* CAD drawings may not reflect diameter, thread length or overall length.

© Bolt & Nut Australia Pty Ltd. All rights reserved.

Version: 18 Mar 2024